

GD150 Compressor

Maximum 117m³/hr (69 cfm) at 2.5 bar g (36 psig)

Market

The GD150 is a lightweight, compact rotary vane compressor designed for the oil free discharge of bulk liquids from general purpose tankers, e.g. liquid foodstuff, solvents, acids, alkalis, hot bitumen, resins and other chemicals.

The main benefit of using a compressor to discharge liquid is that the product does not come into contact with the machine. This eliminates the problems of compatibility between the liquid and the compressor components.



DRUM
A Gardner Denver Product

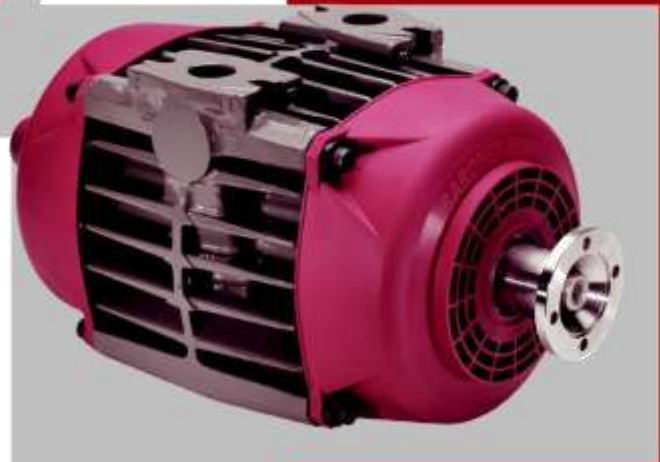
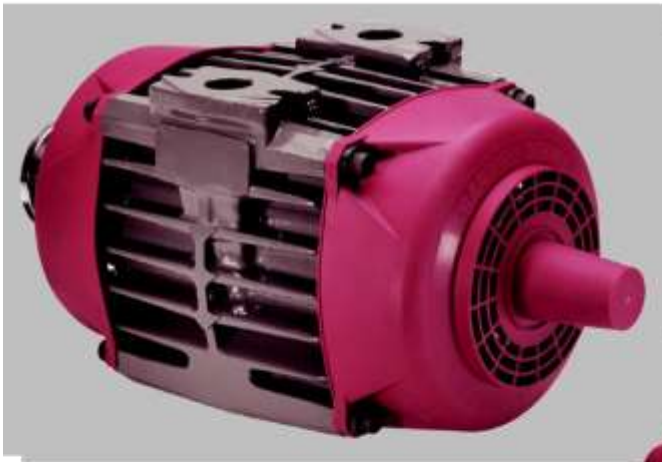

Specification

General Design

The machine is an oil free sliding vane design supported by bearing arrangements at both ends of the rotor.

All the components used in the main bore cavity are hard anodised aluminium or stainless steel to maximise the resistance to atmospheric corrosion.

Mounting

The compact size and shape of the compressor make it ideal for simple mounting inside the chassis on most vehicles to enable low cost direct PTO driving.

The through shaft allows CW or ACW input drive rotation and the compressor can be installed in 3 orientations to provide the maximum mounting flexibility.

The Standard Package

The standard package consists of the following equipment:

- Basic GD150 machine and mounting kit
- Induction kit including cyclonic inlet filter
- Relief valve
- Check valve
- Stainless steel discharge flange pack

**Vane Type
Compressors**

■ GD150

GD150 COMPRESSOR

Dimensions

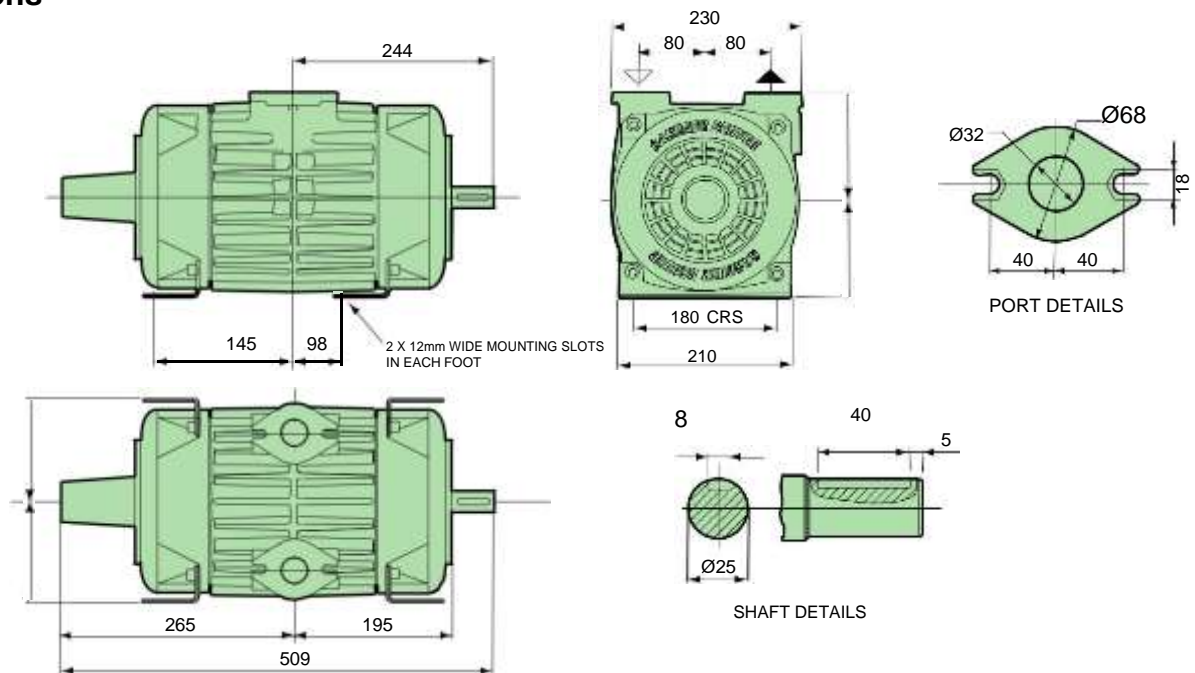

Weight GD150: 32kg

Optional ancillaries

- Silencer
- Delivery filter
- Various flange packs as required
- Various drive flanges

Drive options

- Prop. shaft drive:** Direct from a vehicle PTO
- Hydraulic drive:** Several drives can be offered depending on the application
- Electric motor drive:** Packages on base frames
- Engine drive:** Packages on base frames

Performance

Flow Rate and Input Power

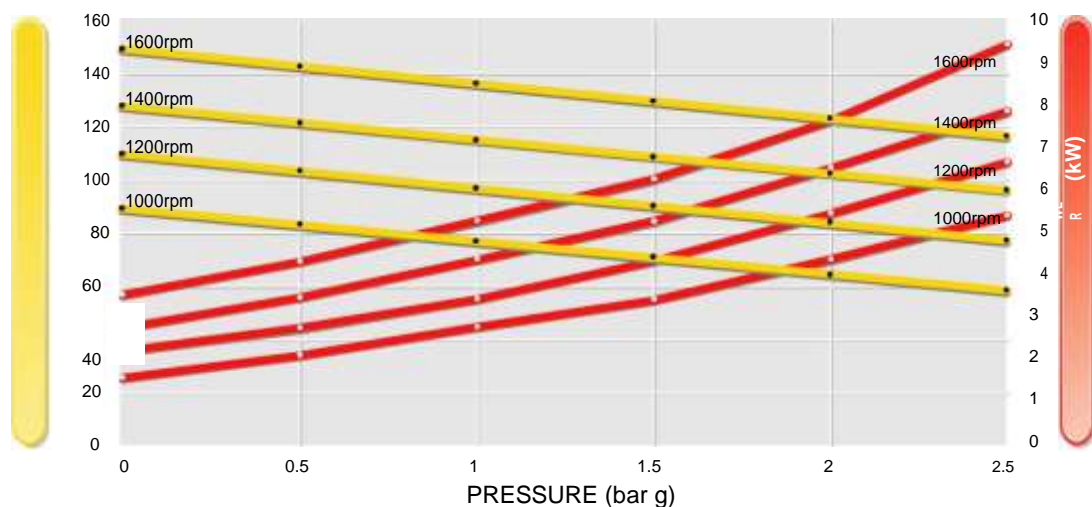

Flow measured in accordance with BS1042/ISO 5167-1/BS ISO TR 15377 and referred to standard ambient conditions (1013 mbar, 20°C)

IN ORDER TO CONTACT THE GARDNER DENVER DISTRIBUTOR AUTHORIZED IN ITALY

GENERAL SERVICE SRL
Via Difesa Maddalena, 6
84022 Campagna (SA)
Italia

Telefono: +39 338 6757132
Fax: +39 0828 1772513
Email: info@general-service.it
Web: www.general-service.eu